

Grant® By-Pass Door Sets with Fascia for Sliding Doors

Top Line Grant 6065

up to 75 lbs/door (34 kg/door), double track with fascia,
for door thickness $\frac{3}{4}$ " (19 mm), side mount, adjustable



Top Line Grant 6065

A medium duty sliding door hardware series with fascia track for by-passing installations. Applications include doors between rooms, closet doors, cabinets, storage walls and partitions.

- For $\frac{3}{4}$ " doors weighing up to 75 lbs/door (34 kg/door)
- Ball-bearing wheels guarantee a smooth, quiet and long lasting performance.
- Dual set of mounting holes; ideal for hollow core doors
- Aluminum track with $1\frac{1}{2}$ " fascia, decorative anodized finish
- Easy-turn cam vertical adjustment
- Pivoting rocker arms ensure track-carrier contact.
- Dust free track design
- Quick door hanging by tilting pre-mounted hardware onto track profile
- Made in USA

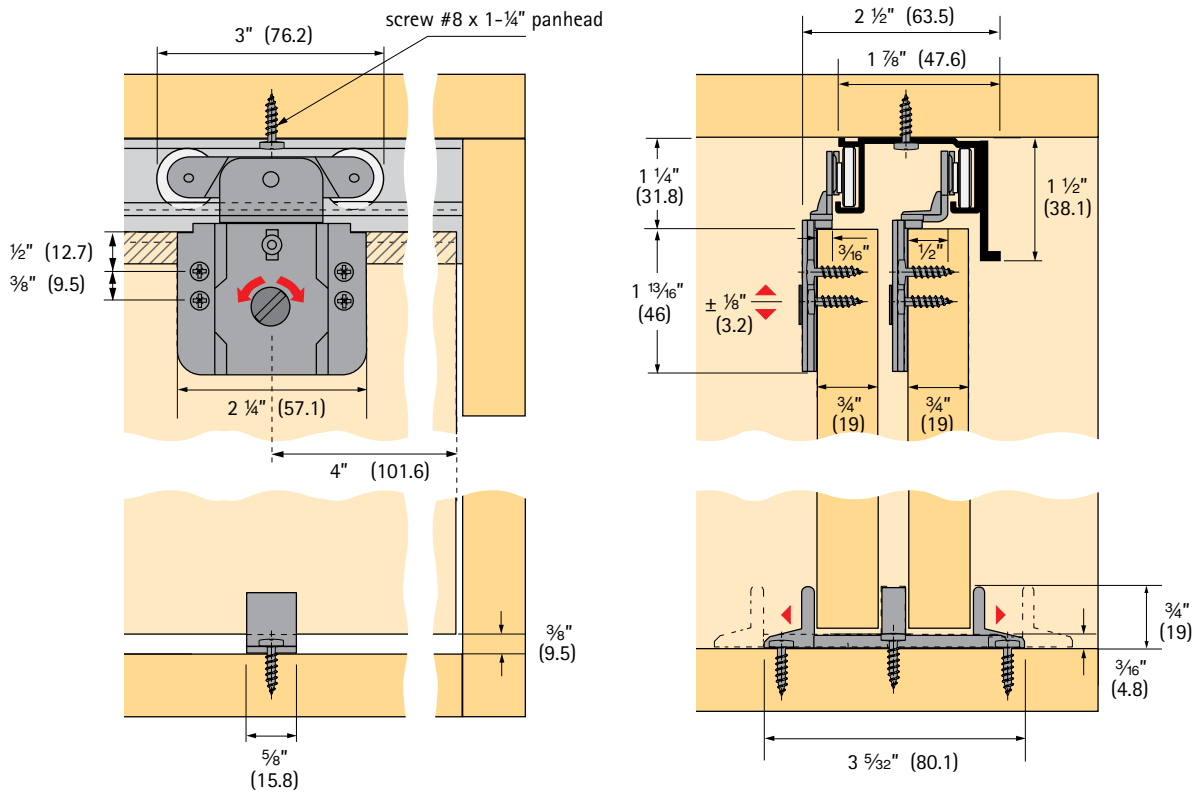
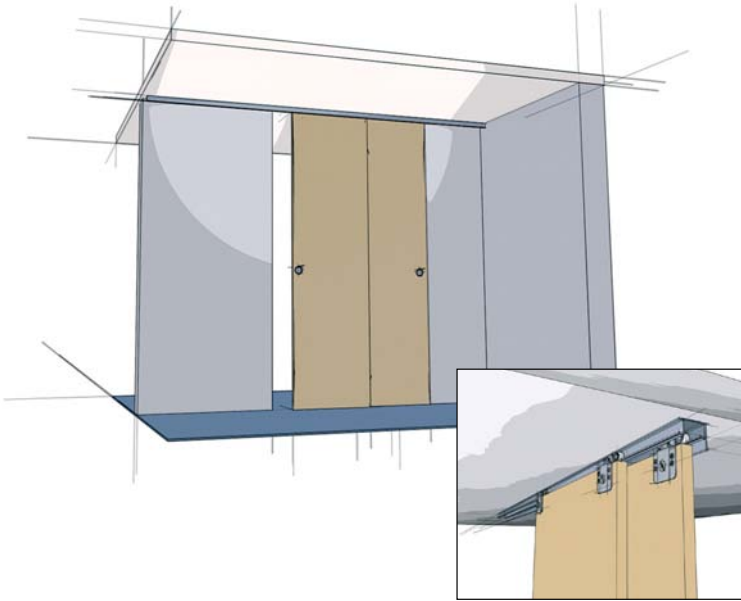

Specifications:

Mounting: Side
 Adjustment: ¼" (6.4 mm) vertical
 Door thickness: ¾" (19 mm)
 Headroom: 1½" (28.6 mm) min., 1¾" (34.9 mm) max.
 Application: By-passing

Top Line Grant 6065 door hardware is available in four purchasing options
Option I

Complete package: includes track, hardware set, and all screws

Length	Order no.	PU
4' (1200 mm)	113 333 0	10 sets
6' (1800 mm)	113 333 1	10 sets

For longer track application order hardware set and track separately

Option II

Track only

Double track with fascia 6005

Aluminum extruded, pre-drilled holes

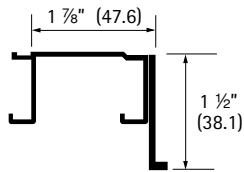

Length	Order no.	PU
8' (2400 mm)	050 475	5
12' (3600 mm)	050 477	5

Screws not included - recommend #8 Pan Head

Option III

Hardware set only

Top Line Grant 6064 hardware set
 (without track)

The hardware set includes:
 2 carriers 6350 ball bearing wheels
 2 carriers 6360 ball bearing wheels
 1 floor guide 114
 necessary screws
 installation instructions

Article	Order no.	PU
Hardware set	113 332 5	10 sets

Option IV

Separate components

Top Line Grant 6065 components**Carrier 6350**

Steel, double wheel, ⅜" offset, side mounting, adjustable, ball bearing wheels, dual mounting holes

Screws included



Finish	Order no.	PU
zinc-plated	113 333 6	50

Carrier 6360

Steel, double wheel, ½" offset, side mounting, adjustable, ball bearing wheels, dual mounting holes

Screws included



Finish	Order no.	PU
zinc-plated	113 333 7	50

Floor guide 114
 Nylon
 Adjustable for ¾" to 1 ⅜" doors
 Screws included

Finish	Order no.	PU
N/A	050 102	50

Top Line Grant 73-034

up to 150 lbs/door (68 kg/door), double track with fascia,
for door thickness $\frac{3}{4}$ " (19 mm), side mount, adjustable

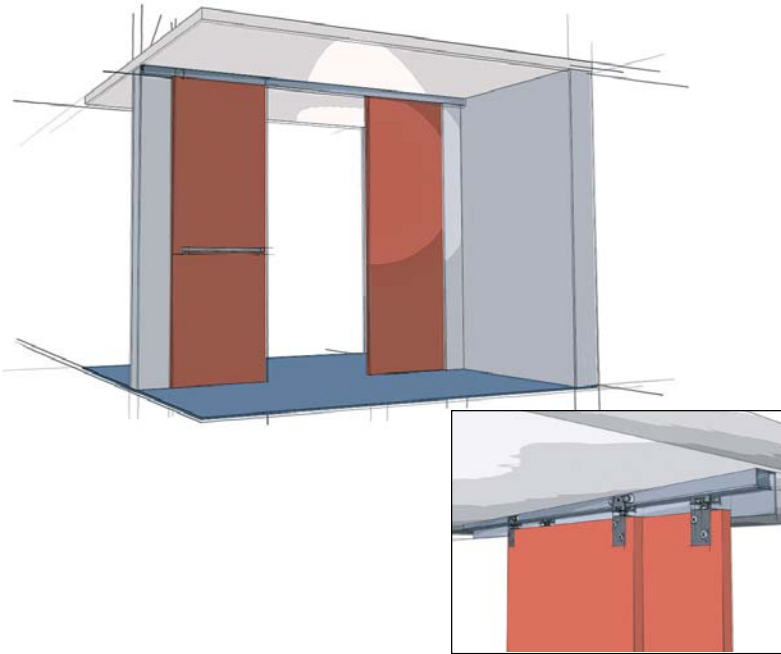

Top Line Grant 73-034

A medium duty commercial and residential grade sliding door hardware series with fascia that is ideal for by-passing installations. Applications include doors between rooms, closet doors, cabinets, storage walls and partitions.

- For $\frac{3}{4}$ " doors weighing up to 150 lbs (68 kg), optional nylon wheel carrier up to 100 lbs (45 kg)
- Precision ball-bearing wheels guarantee a smooth, quiet and long lasting performance.
- Heavy duty aluminum Double I-beam track; jump proof design
- Track with $2 \frac{3}{8}$ " fascia, decorative anodized finish
- Pivoting rocker arms ensure track-carrier contact.
- Ball and socket suspension compensates for minor header misalignment.
- Lock nut guarantees permanent positioning.
- Serrations in apron permit vertical adjustment.
- Conforms to ANSI/BHMA standards, Grade 1
- Made in USA

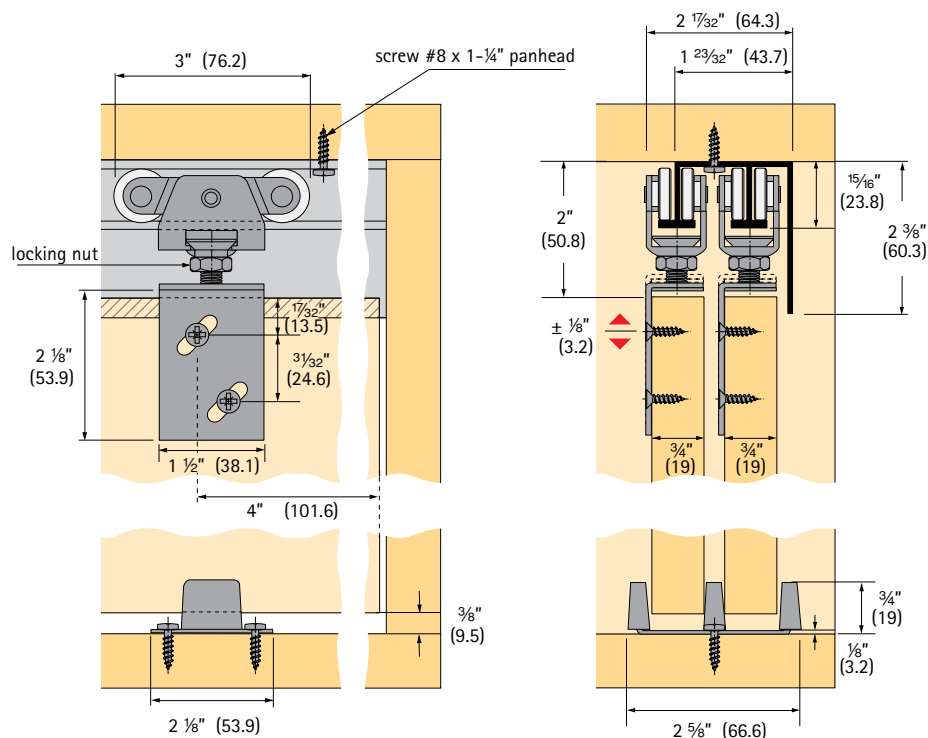

Technical specifications are subject to change without notice

Specifications:

Mounting: Side
 Adjustment: 1/4" (6.4 mm) vertical
 Door thickness: 3/4" (19 mm)
 Headroom: 1 7/8" (47.6 mm), 2 1/8" (53.9 mm) max.
 Application: By-passing

Top Line Grant 73-034 door hardware is available in three purchasing options (not available in sets)

Option I
Track only

Double track with fascia 7004

Aluminum extruded, pre-drilled holes

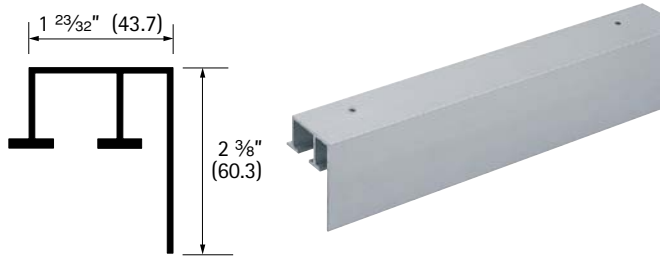

Length	Order no.	PU
4' (1200 mm)	050 540	5
5' (1500 mm)	050 541	5
6' (1800 mm)	050 542	5
8' (2400 mm)	050 543	5
10' (3000 mm)	050 544	5
12' (3600 mm)	050 545	5
16' (4800 mm)	050 546	5

Screws not included - recommend #8 Pan Head
 Tracks 8' and under are notched at one end for easy access

Option II
Hardware set only

Top Line Grant 72-034 hardware set
(without track)

The hardware set includes:
 4 carriers 7000 precision ball bearing wheels
 4 aprons 7034
 1 floor guide 116
 1 wrench
 necessary screws and installation instructions

Article	Order no.	PU
Hardware set	113 335 0	10 sets

Option III
Separate components

Top Line Grant 73-034 components

Carrier 7000 ball bearing

Steel, precision ball bearing wheels, up to 150 lbs/door (68 kg/door)



Finish	Order no.	PU
zinc-plated	113 333 9	100

Apron 7034

Cold rolled steel, adjustable, 3/4" offset

Screws included



Finish	Order no.	PU
zinc-plated	050 563	100

Floor guide 116

Steel/Nylon

Screws included



Finish	Order no.	PU
zinc-plated	050 103	50

Optional parts (not included in set)

Carrier 7000 nylon

Steel, wheel nylon, up to 100 lbs/door (45 kg/door)



Finish	Order no.	PU
zinc-plated	113 333 8	100

Bumper stop 7014

Steel, track mounted, rubber stop, 2 required per track



Finish	Order no.	PU
zinc-plated	050 561	20

Top Line Grant 73-138

up to 150 lbs/door (68 kg/door), double track with fascia,
for door thickness 1 3/8" (34.9 mm), side mount, adjustable

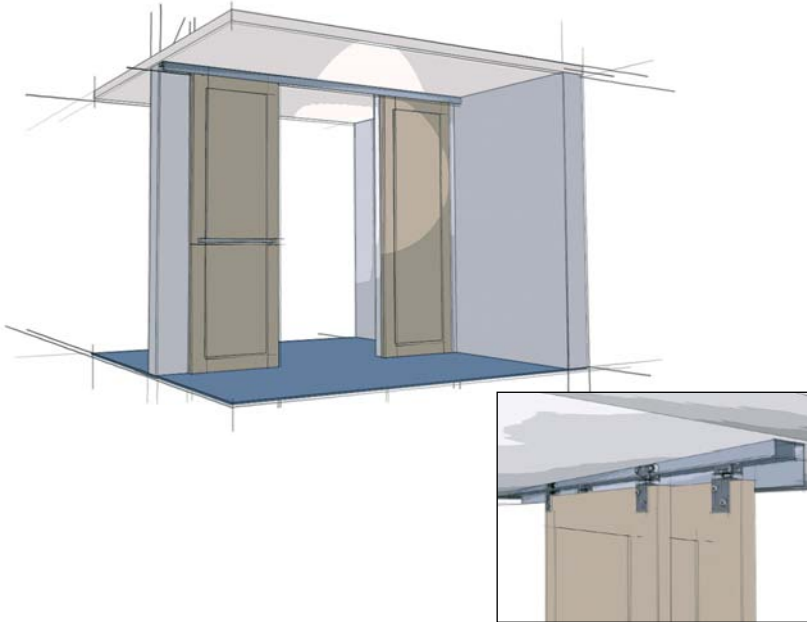

Top Line Grant 73-138

A medium duty commercial and residential grade sliding door hardware series with fascia for by-passing installations. Applications include doors between rooms, closet doors, closets, cabinets, storage walls and partitions.

- For 1 3/8" doors weighing up to 150 lbs (68 kg), optional nylon wheel carrier up to 100 lbs (45 kg)
- Precision ball-bearing wheels guarantee a smooth, quiet and long lasting performance.
- Heavy duty aluminum Double I-beam track; jump proof design
- Track with 2 3/8" fascia, decorative anodized finish
- Pivoting rocker arms ensure track-carrier contact.
- Ball and socket suspension compensates for minor header misalignment.
- Lock nut guarantees permanent positioning.
- Serrations in apron permit vertical adjustment.
- Conforms to ANSI/BHMA standards, Grade 1
- Made in USA

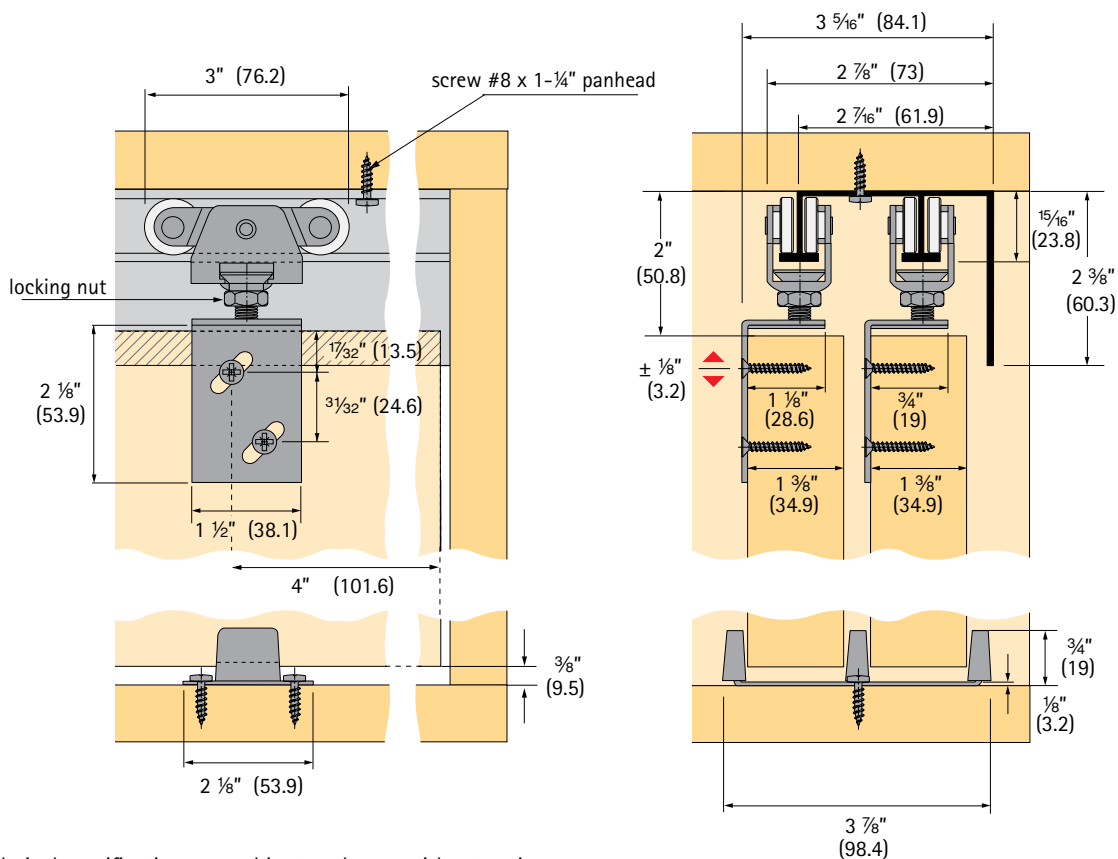

Technical specifications are subject to change without notice

Specifications:

Mounting: Side
 Adjustment: ¼" (6.4 mm) vertical
 Door thickness: 1¾" (34.9 mm)
 Headroom: 1⅞" (47.6 mm) min., 2⅞" (53.9 mm) max.
 Application: By-passing

Top Line Grant 73-138 door hardware is available in four purchasing options**Option I**

Complete package: includes track, hardware set, and all screws

Hardware and track

Length	Order no.	PU
4' (1200 mm)	113 338 2	5 sets
5' (1500 mm)	113 338 3	5 sets
6' (1800 mm)	113 338 4	5 sets
8' (2400 mm)	113 338 5	5 sets

For longer track application order hardware set and track separately

Option II

Track only

Double track with fascia 7005

Aluminum extruded, pre-drilled holes

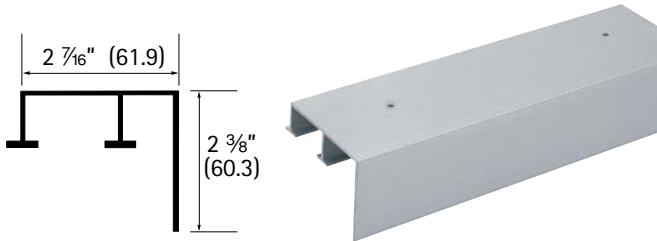

Length	Order no.	PU
5' (1500 mm)	050 548	5
6' (1800 mm)	050 549	5
8' (2400 mm)	050 550	5
10' (3000 mm)	050 551	5
12' (3600 mm)	050 552	5
16' (4800 mm)	050 553	5

Screws not included - recommend #8 Pan Head

Tracks 8' and under are notched at one end for easy access

Option III

Hardware set only

Top Line Grant 72-138 hardware set
(without track)

The hardware set includes:

- 4 carriers 7000 precision ball bearing wheels
- 4 aprons 7138
- 1 floor guide 117
- 1 wrench
- necessary screws and installation instructions

Article	Order no.	PU
Hardware set	113 336 3	10 sets

Option IV

Separate components

Top Line Grant 73-138 components**Carrier 7000 ball bearing**Steel, precision ball bearing wheels,
up to 150 lbs/door (68 kg/door)

Finish	Order no.	PU
zinc-plated	113 333 9	100

Apron 7138Cold rolled steel,
adjustable, 1 ⅞" offset

Screws included



Finish	Order no.	PU
zinc-plated	050 565	100

Floor guide 117

Steel/Nylon

Screws included



Finish	Order no.	PU
zinc-plated	050 104	50

Optional parts (not included in set)**Carrier 7000 nylon**Steel, wheel nylon,
up to 100 lbs/door (45 kg/door)

Finish	Order no.	PU
zinc-plated	113 333 8	100

Bumper stop 7014Steel, track mounted,
rubber stop, 2 required per track

Finish	Order no.	PU
zinc-plated	050 561	20

Top Line Grant 73-134

up to 150 lbs/door (68 kg/door), double track with fascia, for door thickness 1 3/4" (44.4 mm), side mount, adjustable



Top Line Grant 73-134

A medium duty commercial and residential grade sliding door hardware series with fascia for by-passing installations. Applications include doors between rooms, closet doors, cabinets, storage walls and partitions.

- For 1 3/4" doors weighing up to 150 lbs (68 kg), optional nylon wheel carrier up to 100 lbs (45 kg)
- Precision ball-bearing wheels guarantee a smooth, quiet and long lasting performance.
- Heavy duty aluminum Double I-beam track; jump proof design
- Track with 2 3/8" fascia, decorative anodized finish
- Pivoting rocker arms ensure track-carrier contact.
- Ball and socket suspension compensates for minor header misalignment.
- Lock nut guarantees permanent positioning.
- Serrations in apron permit vertical adjustment.
- Conforms to ANSI/BHMA standards, Grade 1
- Made in USA

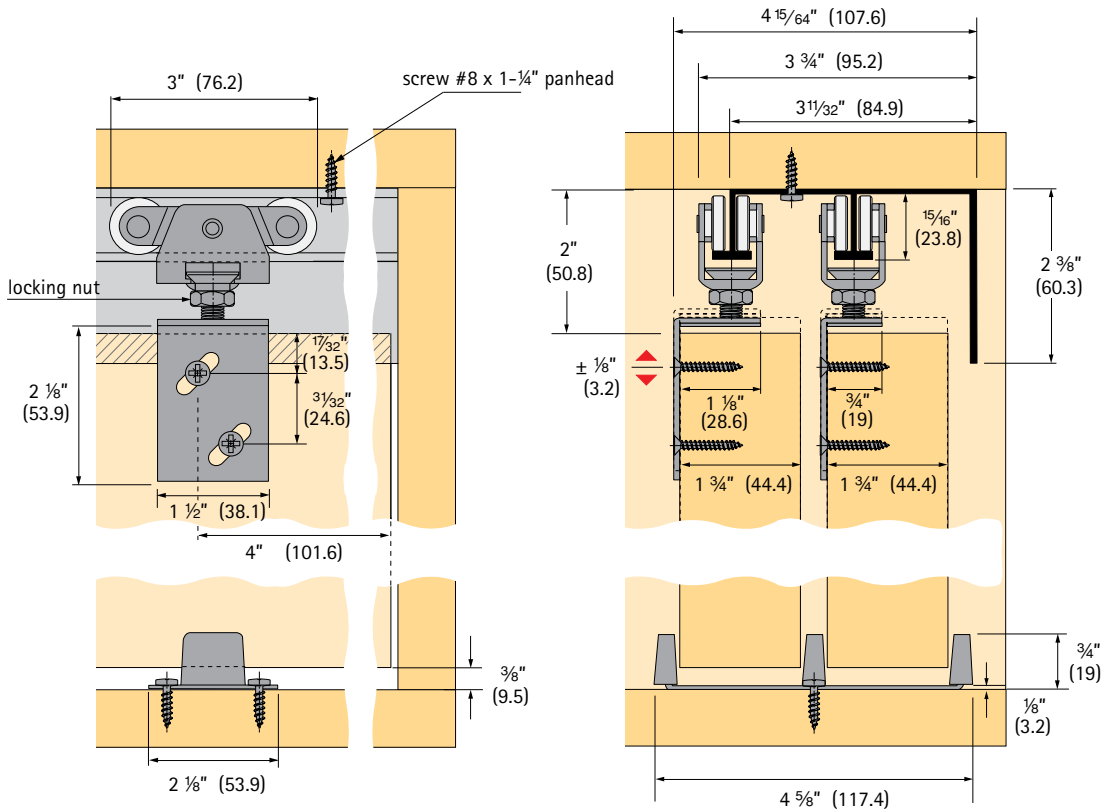
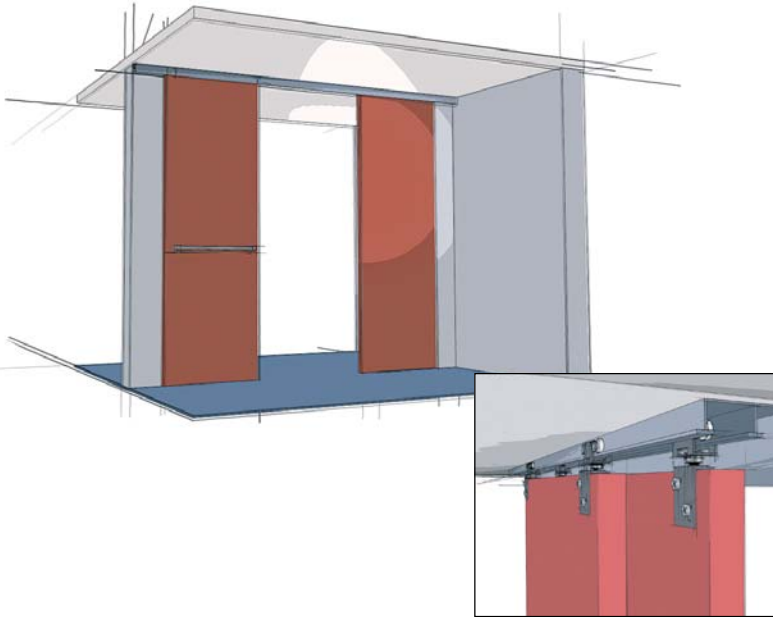

Technical specifications are subject to change without notice

Specifications:

Mounting: Side
 Adjustment: 1/4" (6.4 mm) vertical
 Door thickness: 1 3/4" (44.4 mm)
 Headroom: 1 7/8" (47.6 mm) min., 2 1/8" (53.9 mm) max.
 Application: By-passing

Top Line Grant 73-134 door hardware is available in four purchasing options

Option I

Complete package: includes track, hardware set, and all screws

Hardware and track

Length	Order no.	PU
4' (1200 mm)	113 337 8	5 sets
5' (1500 mm)	113 337 9	5 sets
6' (1800 mm)	113 338 0	5 sets
8' (2400 mm)	113 338 1	5 sets

For longer track application order hardware set and track separately

Option II

Track only

Double track with fascia 7007

Aluminum extruded, pre-drilled holes

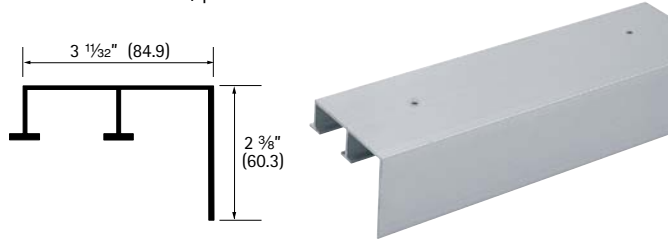

Length	Order no.	PU
5' (1500 mm)	050 555	5
6' (1800 mm)	050 556	5
8' (2400 mm)	050 557	5
10' (3000 mm)	050 558	5
12' (3600 mm)	050 559	5
16' (4800 mm)	050 560	5

Screws not included - recommend #8 Pan Head
 Tracks 8' and under are notched at one end for easy access

Option III

Hardware set only

Top Line Grant 72-134 hardware set
 (without track)

The hardware set includes:
 4 carriers 7000 precision ball bearing wheels
 2 aprons 7034 (front door)
 2 aprons 7138 (rear door)
 1 floor guide 118
 1 wrench
 necessary screws and installation instructions

Article	Order no.	PU
Hardware set	113 335 8	10 sets

Option IV

Separate components

Top Line Grant 73-134 components

Carrier 7000 ball bearing

Steel, precision ball bearing wheels,
 up to 150 lbs/door (68 kg/door)



Finish	Order no.	PU
zinc-plated	113 333 9	100

Apron 7034/7138

Cold rolled steel,
 adjustable

Screws included



Article	Finish	Order no.	PU
1 apron 7034, 3/4" offset	zinc-plated	050 563	100
2 apron 7138, 1 1/8" offset	zinc-plated	050 565	100

Floor guide 118

Steel/Nylon

Screws included



Finish	Order no.	PU
zinc-plated	050 105	50

Optional parts (not included in set)

Carrier 7000 nylon

Steel, wheel nylon,
 up to 100 lbs/door (45 kg/door)



Finish	Order no.	PU
zinc-plated	113 333 8	100

Bumper stop 7014

Steel, track mounted,
 rubber stop, 2 required per track



Finish	Order no.	PU
zinc-plated	050 561	20

